

INSTRUCTIONS-PARTS LIST



801-888

Rev B

This manual contains **IMPORTANT**
WARNINGS and **INSTRUCTIONS**
READ AND RETAIN FOR REFERENCE

HYDRA-CLEAN® 826 **Pressure Washer**

P/N 800-093 SERIES "A" — CART MODEL
P/N 800-094 SERIES "A" — HANDLE MODEL

800 psi (55 bar) OPERATING PRESSURE

1100 psi (76 bar) MAXIMUM WORKING PRESSURE

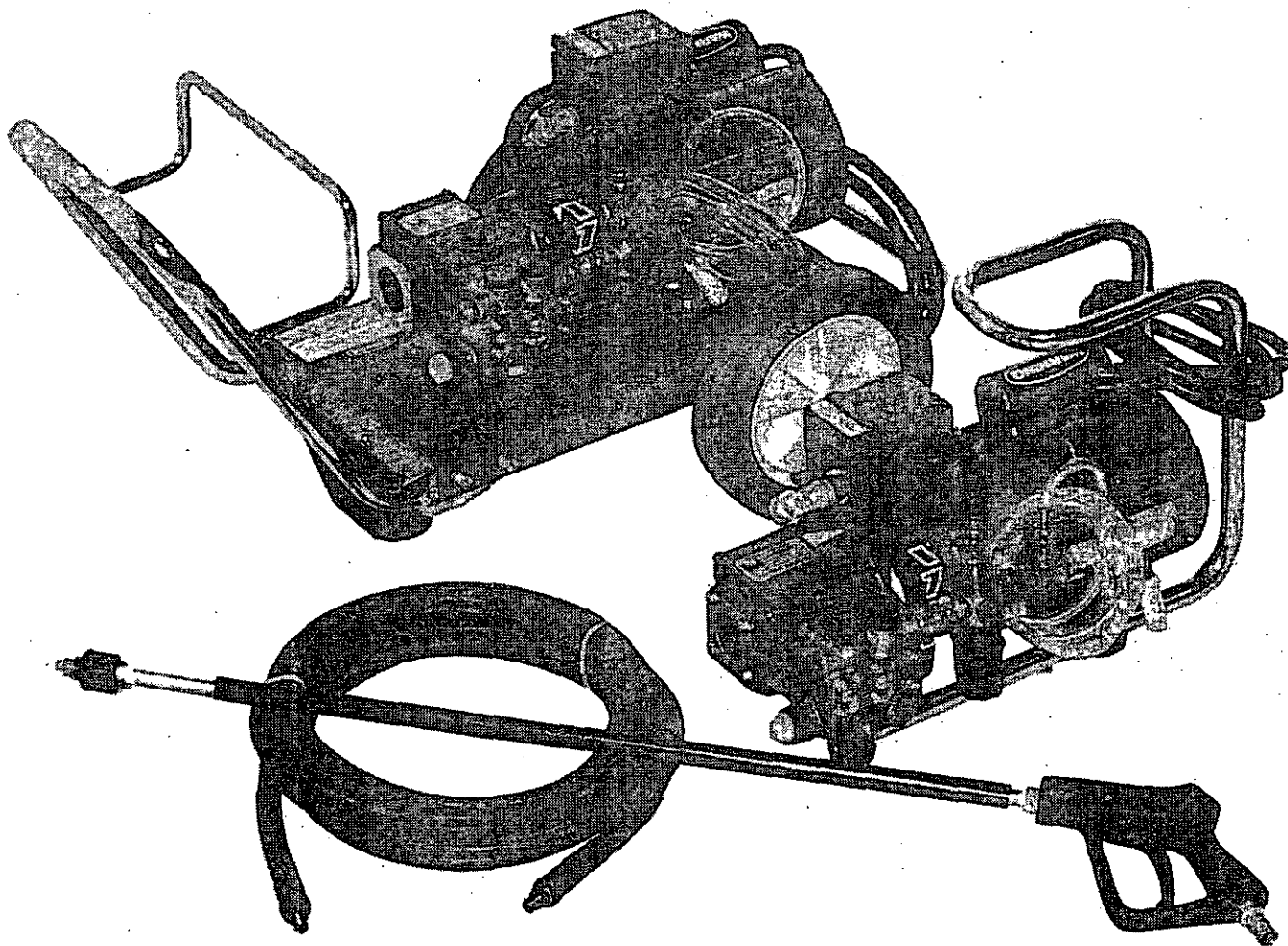

GRACO INC. P.O. Box 1441 MINNEAPOLIS, MN 55440-1444

© COPYRIGHT 1984 GRACO INC.

WARNING

**HIGH PRESSURE SPRAY CAN CAUSE SERIOUS INJURY.
FOR PROFESSIONAL USE ONLY.
OBSERVE ALL WARNINGS.**

Read and understand all instruction manuals before operating equipment.

INJECTION HAZARD

Fluids under high pressure from spray or leaks can penetrate the skin and cause extremely serious injury, including the need for amputation.

NEVER point the spray gun at anyone or any part of the body.

NEVER put hand or fingers over the spray tip.

NEVER try to stop or deflect leaks with your hand or body.

MEDICAL TREATMENT

If any fluid appears to penetrate your skin, get **EMERGENCY MEDICAL CARE AT ONCE.**

DO NOT TREAT AS A SIMPLE CUT.

Tell the doctor exactly what fluid was injected. For treatment instructions have your doctor call the **NATIONAL POISON CENTER NETWORK**
(412) 681-6669

AVOID COMPONENT RUPTURE

Even after you shut off the electric motor, there is high pressure in the pump, hose and gun until you release it by triggering the gun. So before removing the spray tip or servicing the unit, *always* shut off the unit *and* trigger the gun to release pressure.

Be sure that all accessory items and system components will withstand the pressure developed. **NEVER** exceed the pressure rating of any component in system. **NEVER** alter or modify equipment—your personal safety, as well as the function of the equipment, is at stake.

Before each use, check hose for weak, worn or damaged conditions caused by traffic, sharp corners, pinching or kinking. Tighten all fluid connections securely before each use. Replace any damaged hose.

Do not use chemicals or agents which are not compatible with Viton and PVC or neoprene cover of hose.

Do not leave a pressurized unit unattended. Shut off the unit and release pressure before leaving.

FIRE

Do not spray flammable liquids. Do not operate the unit where combustible fumes or dust may be present.

GENERAL

Observe detergent manufacturer's safety precautions. Avoid getting detergent or other liquids in your eyes. Follow the directions on the container regarding contact with eyes, nose, and skin, breathing fumes, etc. Always wear full goggles to protect your eyes from the spray as well as any debris dislodged by the spray. If necessary, wear gloves or other protective clothing. If antidotes or treatment are recommended, be prepared to use them.

DON'T spray toxic chemicals such as insecticide or weed killer.

This unit is supplied with an 8-foot power cord made up of three AWG No. 14 wires. The green wire of the electric cord is connected to the unit chassis and motor frame. The other two wires are connected to the starter switch.

The starter switch has a built-in ground fault interrupter that will shut off the power to the unit whenever an improper ground condition exists.

Always check to be sure the switch is off and that the hoses and electric cord are clear of moving parts before plugging in the power cord.

IMPORTANT

United States Government safety standards have been adopted under the Occupational Safety and Health Act. These standards—particularly the General Standards, Part 1910, and the Construction Standards, Part 1926—should be consulted in connection with your use of airless spray equipment.

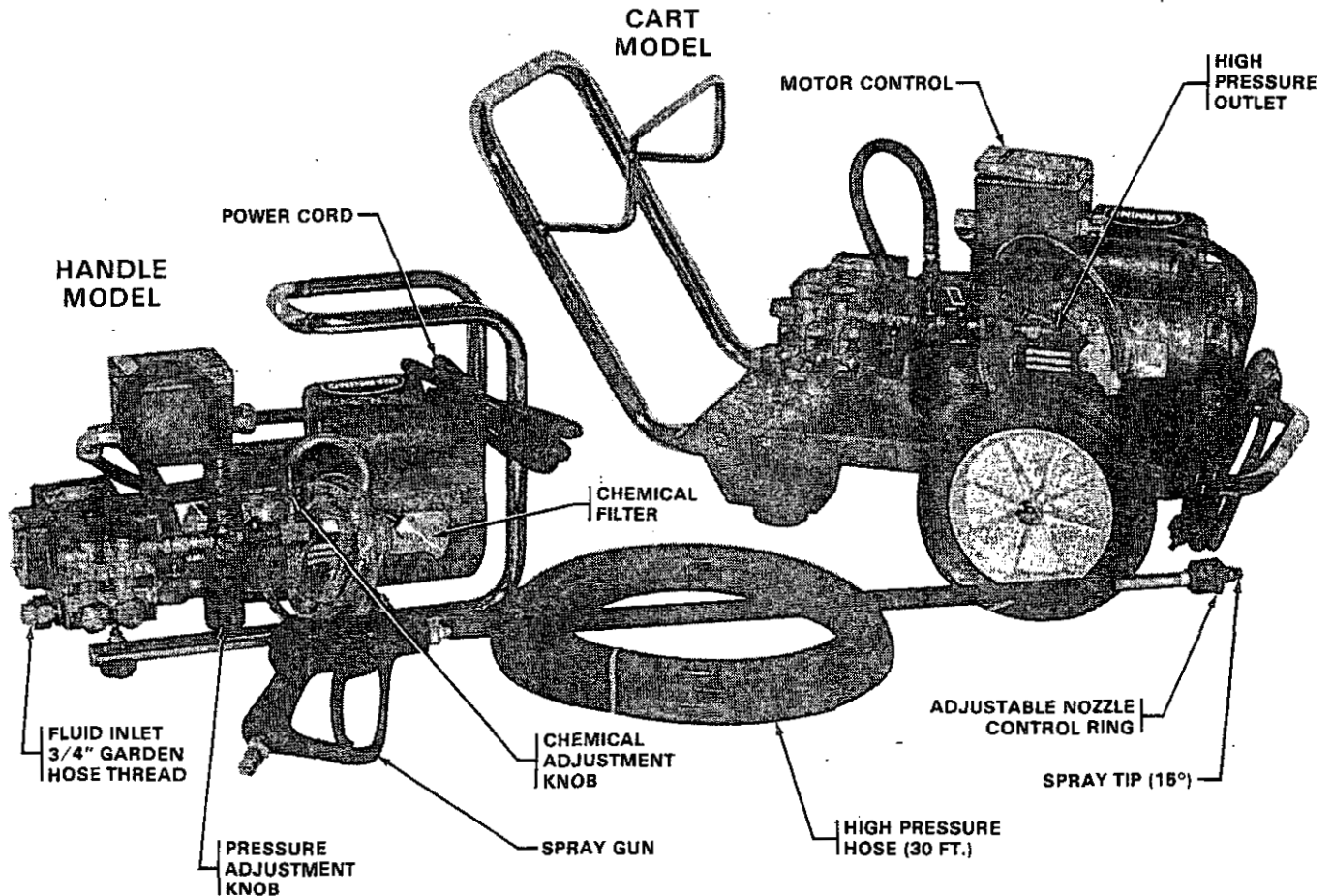

Check For Damage

Check unit for any damage that may have occurred in shipping. Any damage should be noted and the carrier notified immediately.

Check unit and accessories to be sure that all components were included. If anything is missing contact your local representative.

Handle Model

The handle unit comes completely assembled. The installation of hose, gun and connection to water supply, as described later, is all that is required.

Cart Model

The cart unit comes partially assembled. Refer to the parts drawing on page 7 for aid when following assembly procedures.

Install axle and wheels by inserting axle through axle support tube which is attached to chassis. Place a washer, a wheel, and another washer on the axle on both sides of the chassis. Insert a cotter pin into the hole at each end of the axle. Bend cotter pins over so they won't fall out.

Attach leg assembly and handle by putting the leg assembly directly under the unit towards the front of

the chassis. Insert the flattened tabs on the handle through the slots in the front edge of the chassis. Align holes and insert the four hex head machine screws (3/8-16 NC x 1-1/4 inch) with flat washer, lock washer and nut and firmly tighten.

Spray Gun/Hose

Assemble spray gun by attaching the spray wand with its safety grip to the gun handle. The wand comes with PTFE tape on the pipe threads at each end. Attach the adjustable spray nozzle to the other end of the wand. Tighten securely to avoid any leaking.

Attach one end of the high pressure hose to the spray gun and the other end to the high pressure outlet. Tighten swivel connections firmly using two wrenches.

Spray Hose

A 30 foot (9.1 m) section of high pressure hose is supplied with this model. Additional sections may be ordered to increase the hose length. Be aware that adding additional spray hose will lower the pressure of the unit at the spray gun and decrease suction of the chemical injector. Maximum recommended hose length is 90 feet (27 m).

Connect To Water Supply

CAUTION

Before attaching to water supply, check local plumbing codes regarding cross-connection to water supply. Optional back flow preventor P/N 801-133 is available to prevent the back-up of contaminated water into fresh water supply.

Do not exceed 160°F (70°C) water temperature to pump in a direct supply system.

Connect a hose with at least 3/4 inch (19 mm) I.D. from your city water supply to the units 3/4 inch garden hose threaded inlet. The supply hose should not be longer than 50 feet (15 m) long.

NOTE: For a direct supply system, your water source at the unit must have a flow rate of at least 4 GPM (15 liter/min).

Electrical Service

Before plugging the sprayer into an approved electrical receptacle be sure that the electrical service is single phase, 115 V, 60 Hz AC, 15 Amp. With the motor control switch in the OFF position, plug the power cord into a grounded outlet. If an extension cord is used, be sure that it has a ground and that the wire gage is at least No. 14 gage wire. The cord should not be over 100 feet (30 m) long. See the operation section for further characteristics on the motor control switch.

OPERATION

Startup

Before starting, be sure to read the safety warnings and startup instructions.

Turn on the water supply.

Trigger the gun to release any back pressure.

WARNING

DO NOT wire or tie the gun trigger into the open or triggered position.

CAUTION

Never run the cleaning unit dry. Costly damage to the pump will result. Always be sure water supply is completely turned on before operating.

Inspect all connections for any leaks. Tighten if necessary.

Motor Control Switch

As indicated earlier in this manual the motor control switch has a built in ground fault interrupter circuit. Due to this special protection feature of the switch, if the switch "ON" button is pushed in while the unit is unplugged, the unit will go into the "ON" mode. When plugged in, unit will immediately start. The switch cannot be turned off until it is energized. Once power is applied to unit, switch can be turned off.

NOTE: Always use the motor control switch when starting and stopping unit. Avoid inadvertently pushing "ON" button when unit is unplugged.

Cleaning

Start unit by lifting the cover on the motor control switch and pushing the "START" button. This button is also marked "RESET". Pull trigger on gun and unit should start spraying.

The spray pattern can be changed by turning the control ring on the adjustable spray nozzle.

With the control ring turned completely counter-clockwise (viewed from front) all water pressure will be directed through the spray tip orifice. In this position the normal spray pattern of 15° will take place.

To change the spray pattern simply turn the control ring clockwise. This will cause a drop in pressure which will activate the downstream chemical injector.

When full strength spraying is desired, turn control ring counterclockwise to closed position.

WARNING

DO NOT attempt to adjust nozzle when spray gun is in use. Be sure that the safety latch on gun is in the ON position before adjusting.

Pressure Adjustment

The pressure washer has been factory adjusted to deliver 800 ±25 PSI (measured at the pump outlet). This is the maximum pressure that this unit is designed for. However, this pressure can be decreased by turning the control knob located on the unloader valve on the outlet side of the pump. Turning the control knob in a clockwise direction (viewed from above the unit) will gradually decrease the output pressure and flow.

Chemical Injector

A downstream chemical injector is provided with the pressure washer. Insert chemical filter that is attached with clear tubing to chemical injector into the top of the desired chemical container.

The chemicals used must be compatible with system components. The standard spray hose is made of Buna-N rubber, and the chemical injector is brass.

WARNING

Observe chemical manufacturer's safety precautions regarding use of goggles, protective clothing or respirators.

Turn control ring on adjustable nozzle clockwise to cause a drop in pressure.

Start pressure washer unit and trigger spray gun. The injector may draw momentarily as system is filling but normally will stop as system builds up to full pressure. To actuate injector, turn chemical adjustment knob out, counterclockwise, until chemical begins to be drawn from the container. After the chemical reaches injector, flow rate may be adjusted by turning the adjustment knob. At two full turns from the closed position of the chemical adjustment knob, maximum chemical flow is obtained. Do not exceed two turns.

Check the distance you will need to hold spray nozzle from surface by test spraying on a scrap of similar material. For soft surfaces, such as wood, hold nozzle about 3 feet (1 m) from surface and gradually bring it closer, check to see if the high pressure spray is damaging the surface.

Mist-wet surface with cleaning solution. Let it soak briefly, then use spray rinse to "chisel" off dirt. Keep nozzle at an angle to surface, and at distance you determined to be best for surface. If some dirt remains, repeat procedure, letting it soak a little longer. Stubborn dirt can be cleaned off better with a stronger, heated cleaning solution.

Protect surfaces that might be damaged by cleaning solution or high pressure spray, and rinse solution before it dries.

Shutdown And Care Of Unit

When unit is not in use, turn off water supply.

When shutting down for the day or weekend, shut off unit, shut off water supply valve, and trigger gun to release pressure. Wipe off the unit with a damp rag.

This model runs with very little noise due to the size of the motor and pump. Be sure that the unit is turned off when not in use. If unit is left running, when not actually using spray gun, the build up of temperature in the by-pass loop of the pump could exceed the manufacturer's specifications of 160°F (71°C) maximum. This will cause shortened pump life.

CAUTION

Shut off cleaning unit when not actually spraying, for longer pump life. The pump will overheat if left running for over 10 minutes without spraying.

Check the filter screen in the water inlet connection as often as necessary, at least daily. Do not operate the unit with the inlet and filter screen removed.

PUMP MUST NOT BE RUN DRY and must be drained of water prior to exposure to freezing temperatures. Use and store the unit where it will not be subjected to freezing temperatures. If water does freeze in the unit, thaw before trying to start. A 50% anti-freeze solution may be pumped prior to cold weather storage.

Use only spray tips that are matched to the unit to avoid excessive cycling and wear of the unloader valve.

CAUTION

Let a frozen pump thaw in a warm place. Don't pour hot water on a frozen pump. A sudden temperature change may crack the ceramic plungers.

Do not pump caustic materials.

Before extended storage, flush the pump with light oil.

Avoid dragging hose over an abrasive surface such as cement. This causes excessive wear and shorter hose life.

Clean the intake line strainer daily.

Lubrication and Care

Fill pump crankcase to dot on oil gauge window with 10.2oz. (0.3 liters) of crankcase oil (part no. 801-144) or equivalent SAE 20/30 weight hydraulic oil with anti-wear and rust inhibitor additives. Change initial fill after 50 hour running period. Change oil every 3 months or at 500 hour intervals.

Winter Maintenance

1. Turn off and disconnect water supply and discharge lines.
2. Pump a 50% antifreeze solution through the machine making sure all water has been displaced.
3. When machine is needed, connect the water supply and circulate the antifreeze from the machine to containers for reuse. When the water flowing from the outlet becomes clear, reconnect discharge lines.

SERVICE Troubleshooting

PROBLEM	CAUSE	SOLUTION
Low Pressure	Worn nozzle. Coupling slippage. Air leak in inlet plumbing. Relief valve stuck, partially plugged or improperly adjusted; valve seat worn. Inlet suction strainer clogged or improper size. Worn packing. Abrasives in pumped fluid or severe cavitation. Inadequate water supply. Fouled or dirty inlet or discharge valves. Worn inlet or discharge valves. Leaky discharge hose. Pressure adjustment set down.	Replace with nozzle of proper size. Tighten or replace. Disassemble, reseal, and reassemble. Clean, and adjust relief valve; check for worn and dirty valve seats. Kit available. Clean. Use adequate size. Check more frequently. Install proper filter. Check flow available to pump. Clean inlet and discharge valve assemblies. Replace worn valves, valve seats and/or discharge hose. Turn adjustment knob counter-clockwise to increase pressure.
Pump runs extremely rough, pressure low.	Restricted inlet or air entering the inlet plumbing. Inlet restrictions and/or air leaks. Stuck inlet or discharge valve. Leaking high pressure seals.	Proper size inlet plumbing; check for air tight seal. Clean out foreign material, replace worn valves. Replace seals.
Water leakage from under the manifold.	Worn packing.	Install new packing.
Water in pump crankcase.	May be caused by humid air condensing into water inside the crankcase.	Change oil at 3 month or 500 hour intervals using Crankcase Oil (other approved oil every month or 200 hours) P.N. 801-144.
Frequent or premature failure of the packing.	Scored plungers. Over pressure to inlet manifold. Damaged or worn plungers. Abrasive material in the fluid being pumped. Excessive pressure and/or temperature of fluid being pumped. Over pressure of pump. Running pump dry.	Replace plungers. Reduce inlet pressure. Replace plungers. Install proper filtration on pump inlet plumbing. Check pressures and fluid inlet temperature; be sure they are within specified range. Reduce pressure. Do not run pump without water.
Strong surging at the inlet and low pressure on the discharge side.	Foreign particles in the inlet or discharge valve, or worn inlet and/or discharge valves.	Check for smooth lap surfaces on inlet and discharge valve seats. Discharge valve seats and inlet valve seats may be lapped on a very fine oil stone.
Unit will not start.	Unit not plugged in. G.F.I.C. activated. Electric motor overheated. Electric service off.	Check power cord. Check for proper grounding. Push switch ON (RESET) button. Let motor cool and push reset button on rear of motor. Check fuse/circuit breaker panel.
Chemical injection system doesn't work.	Chemical injector clogged. Adjustable nozzle completely closed. Low chemical level.	Disassemble chemical valve and clean. Check and clean chemical hose and filter. Turn control ring on nozzle clockwise to cause drop in pressure. Check level of chemical.
Spray gun doesn't work or leaks.	Gun cartridge needs replacement.	Replace cartridge (see gun parts drawing).

PARTS DRAWING
Pressure Washer Assembly, 800-093, 800-094

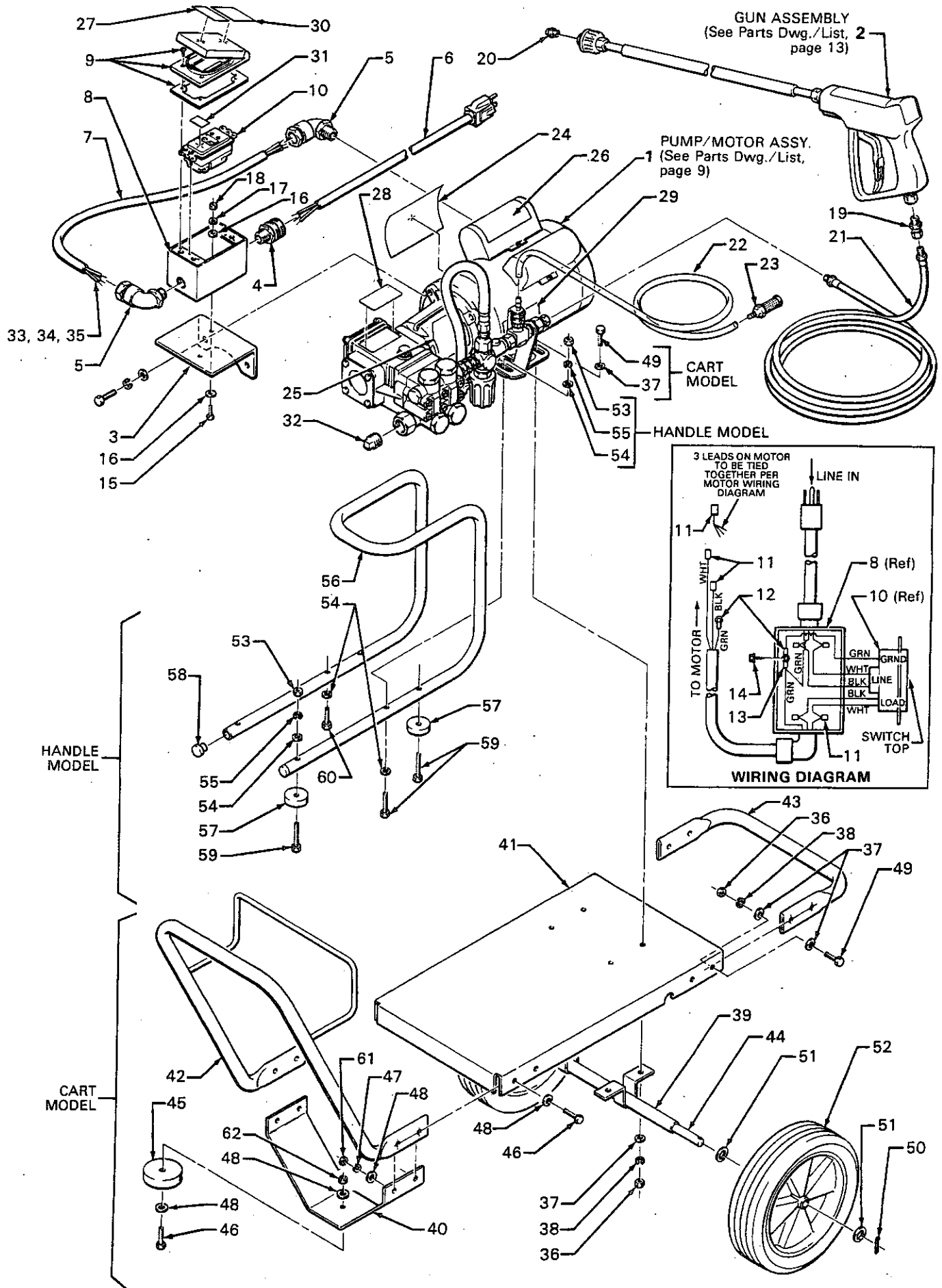

PARTS LIST
Pressure Washer Assembly, 800-093, 800-094

REF. PART NO. NO.	DESCRIPTION	QTY	REF. PART NO. NO.	DESCRIPTION	QTY
800-093	PRESSURE WASHER ASSY., Cart Model (Includes items 1-52, 61, 62)		30 801-902	LABEL, By-Pass	1
800-094	PRESSURE WASHER ASSY., Handle Model (Includes items 1-35, 53-60)		31 801-903	LABEL, Start-Stop	1
1 800-154	PUMP/MOTOR ASSY., see parts drawing, pg. 9	1	32 801-910	PLUG, Plastic	1
2 800-157	GUN ASSY., see parts drawing, pg. 13	1	33 801-228	WIRE, Black	24"
3 801-859	SWITCH MOUNTING BRACKET	1	34 801-229	WIRE, White	24"
4 801-931	CORD GRIP	1	35 801-303	WIRE, Green	24"
5 801-929	CONNECTION, Conduit, 90°	2	36 801-024	NUT, 5/16-18	8
6 801-966	CORD, with 15 Amp Plug	1	37 801-023	FLATWASHER, 1/4	16
7 801-930	CONDUIT, 3/8	18"	38 801-025	LOCKWASHER, 5/16	8
8 801-893	BOX, Switch	1	39 800-155	SUPPORT TUBE WELDMENT	1
9 801-884	COVER, Switch	1	40 801-858	LEG	1
10 801-884	SWITCH/G.F.I.	1	41 801-853	CHASSIS	1
11 801-226	WIRE NUT, Orange	7	42 801-541	HANDLE	1
12 801-304	CRIMP CONNECTOR, Blue	2	43 801-539	BUMPER	1
13 801-221	CRIMP CONNECTOR, YELLOW	1	44 801-857	AXLE	1
14 801-894	SCREW, Self Tapping, #10	1	45 801-504	FOOT, Rubber	1
15 801-605	BOLT, 10-24 x 3/4	2	46 801-546	BOLT, 3/8-16x1-1/4", grade 5	5
16 801-606	FLATWASHER, 3/16	4	47 801-363	LOCKWASHER, 3/8	4
17 801-875	LOCKWASHER, #10	2	48 801-015	FLATWASHER, 5/16	10
18 801-876	NUT, 10-24	2	49 801-941	BOLT, 5/16-18 x 1", grade 5	8
19 801-882	COUPLING, 3/8 NPTM x 1/4 NPSF	1	50 801-880	COTTER PIN, 1/8 Ø x 1-1/4"	2
20 *801-883	TIP, 15065	1	51 801-235	WASHER, 5/8	4
21 801-967	HOSE, High Pressure, 30 ft.	1	52 801-879	WHEEL	2
22 801-677	TUBING, Chemical, 5/16 I.D.	8'	53 801-024	NUT, 5/16-18	6
23 801-683	FILTER, Chemical	1	54 801-023	FLATWASHER, 1/4	8
24 801-129	LABEL, Warning, High Pressure	1	55 801-025	LOCKWASHER, 5/16	6
25 801-008	LABEL, Graco "G"	2	56 801-854	HANDLE, Carrying	1
26 801-388	LABEL, Warning, Ground	1	57 801-886	BUMPER, Rubber	4
27 801-417	LABEL, Relieve Pressure	1	58 801-895	TUBE, Closure	2
28 801-524	LABEL, Oil, Pump	1	59 801-022	BOLT, 5/16-18 x 1-3/4"	5
29 801-501	LABEL, Serial Number	1	60 801-088	BOLT, 5/16-18 x 1-1/2"	1
			61 801-878	NUT, 3/8-16	4
			62 801-499	NUT, Lock, 3/8-16	1

Order parts by name and series letter of the assembly for which you are ordering.

**Recommended "tool box" spare parts.*

PARTS DRAWING
Pump/Motor Assembly, 800-154

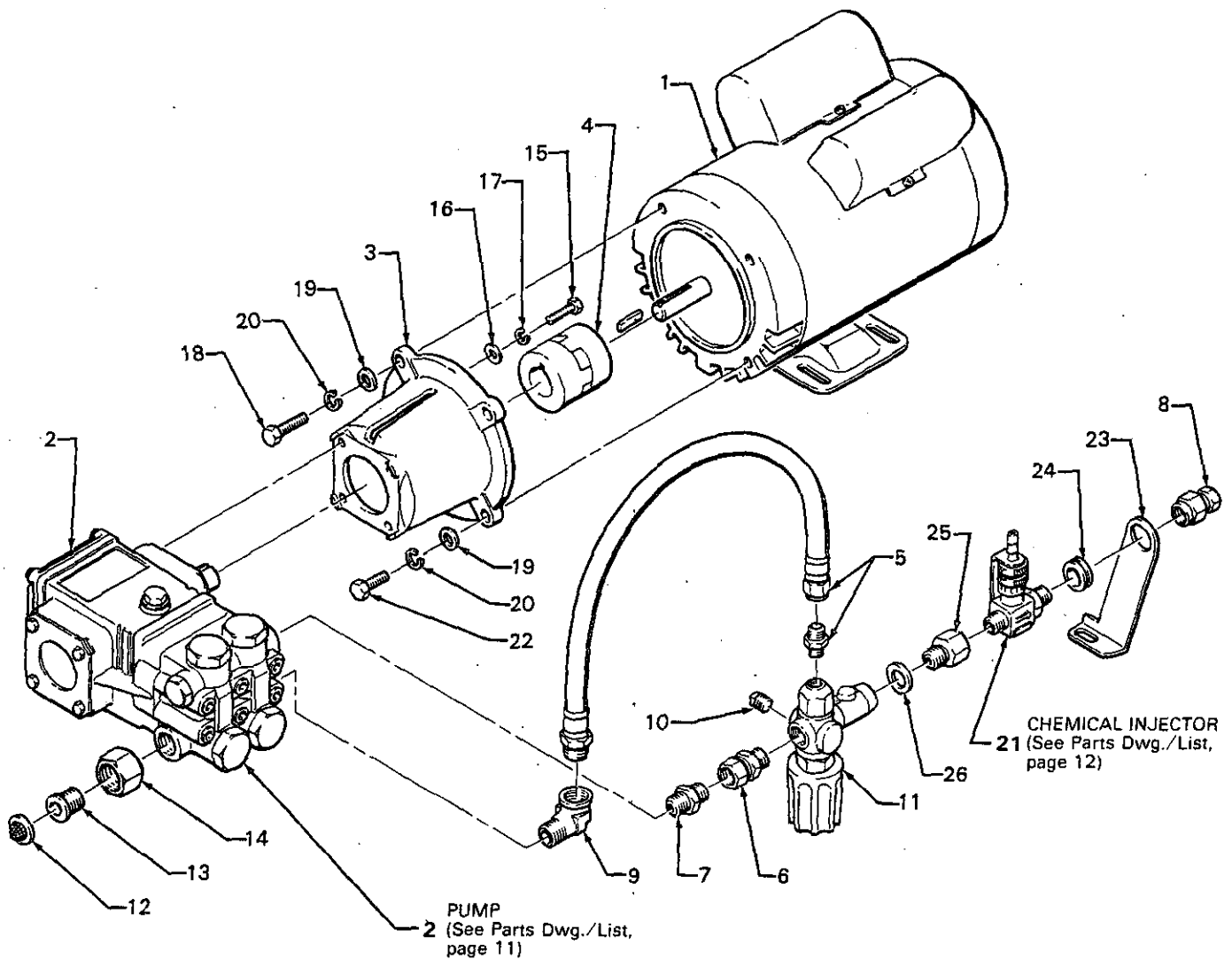

PARTS LIST
Pump/Motor Assembly, 800-154

REF. PART NO. NO.	DESCRIPTION	QTY	REF. PART NO. NO.	DESCRIPTION	QTY
1 801-862	MOTOR, 1.5 hp, "C" Face	1	16 801-023	WASHER, Flat, 1/4	4
2 801-864	PUMP, T-9791, see parts drawing, page 11	1	17 801-139	WASHER, Lock, 1/4	4
3 801-870	COUPLER HOUSING	1	18 801-546	BOLT, Hex Hd., 3/8-16 x 1-1/4	2
4 801-871	COUPLER	1	19 801-015	WASHER, Flat, 5/16	4
5 801-866	HOSE, By-Pass	1	20 801-363	WASHER, Lock, 3/8	4
6 801-890	COUPLING, 3/8 NPTM x 3/8 NPSF	1	21 801-138	CHEMICAL INJECTOR, CHEMJET #2, see parts drawing, pg. 12	1
7 801-891	COUPLING, 3/8 NPTM x 3/8 NPSM	1	22 801-818	BOLT, Hex Hd., 3/8-16 x 1	2
8 801-881	COUPLING, 3/8 NPTF x 1/4 NPSF	1	23 801-901	SUPPORT, Unloader	1
9 801-178	ELBOW, Street, 1/2 NPT	1	24 801-900	GROMMET	1
10 801-709	PLUG, Sq. Hd., 1/4	1	25 801-905	ADAPTOR, 3/8 NPT x G 3/8 B	1
11 801-865	UNLOADER, ST260	1	26 801-907	WASHER, Aluminum	1
12 801-112	SCREEN, Inlet	1			
13 801-110	HOSE ADAPTOR	1			
14 801-111	NUT, Hose Adaptor	1			
15 801-872	BOLT, Hex Hd., M6 x 20 mm	4			

Order parts by name and series letter of the assembly for which you are ordering.

SERVICE

Pump (Refer to Parts Drawing, Page 11)

NOTE: Three sizes of metric wrenches are necessary for servicing the pump; M30, M17, and M6 Allen wrench.

Valves:

1. Remove the hex plug (5) from manifold (6) using M30 wrench.
2. Examine o-ring (4) under plug and replace if cuts or distortion exist.
3. Remove valve unit and o-ring (3) from cavity.

NOTE: Valve unit may come apart during removal.

4. Replace valve unit with P/N 801-472.
5. Replace hex plug and torque to 72.3 ft. lbs. (10 K/m).

NOTE: Hex plug should be re-torqued after 5 hours operation.

Pumping Section:

1. Remove the six Allen head cap screws (1) from the manifold using the M6 Allen wrench.
2. Carefully separate the manifold from the crankcase.

NOTE: It may be necessary to tap manifold lightly with mallet to loosen.

CAUTION

Keep manifold properly aligned with ceramic plungers when removing to avoid damage to plungers or seals.

3. Carefully examine each plunger (19) for any scoring and replace if necessary.

Servicing Plungers:

1. Loosen plunger retaining screw (15) 5-6 turns, using M-17 wrench. Push plunger towards crankcase. This will separate plunger and retaining screw.
2. Remove retaining screw from plunger and examine o-ring (17), back-up ring (18), and copper bearing/gasket washer (16). Replace if necessary using plunger repair kit P/N 801-474.
3. Remove plunger from plunger rod and remove copper flinger (20). Clean or replace if necessary.
4. Lightly grease flinger and replace it on plunger rod.
5. Replace plunger.
6. Lightly grease retaining screw assembly to avoid cutting o-ring. Lightly grease outer end of plunger.

7. Install retaining screw assembly into plunger and torque to 14.4 ft. lbs. (2 K/m).

8. Lubricate each plunger and carefully slide manifold onto crankcase.

9. Replace the six capscrews and snug them up. Torque to 16 ft. lbs. (2.2 K/m).

NOTE: The six capscrews must be torqued evenly to apply equal pressure on the manifold so that it seats properly and doesn't bind or jam. This is best done by torquing bolts closest to the center of the manifold first and then working out from those bolts.

Servicing V-Packings:

NOTE: Use packing repair kit P/N 801-662.

1. After removing the six capscrews and the manifold carefully pull packing retainer (12) from the manifold. Examine o-ring (13) and replace if necessary.
2. Remove low pressure packing (10) and head ring (9).
3. Pull intermediate retainer ring (11) from manifold, high pressure packing (10) and head ring (9).
4. Inspect all parts and replace if necessary.

NOTE: If just the packings are needed use kit 801-662. If rings or retainers need replacement use kit 801-664.

5. Thoroughly clean packing cavity in manifold and examine. Lightly grease packing cavity.
6. Replace packing assembly in the following order: head ring (9), packing (10), intermediate ring (11), head ring (9), packing (10), packing retainer (12), and o-ring (13).

CAUTION

Carefully study the location of each part and the position of the seals to assure proper reassembly and operation.

7. Lubricate each plunger and carefully slide manifold onto crankcase.

NOTE: When replacing the manifold onto plungers, extreme caution should be exercised to avoid damage to the seals.

8. Replace the six capscrews in the manifold and tighten as previously described (step 9 under servicing plungers).

PARTS DRAWING
Pump, 801-864

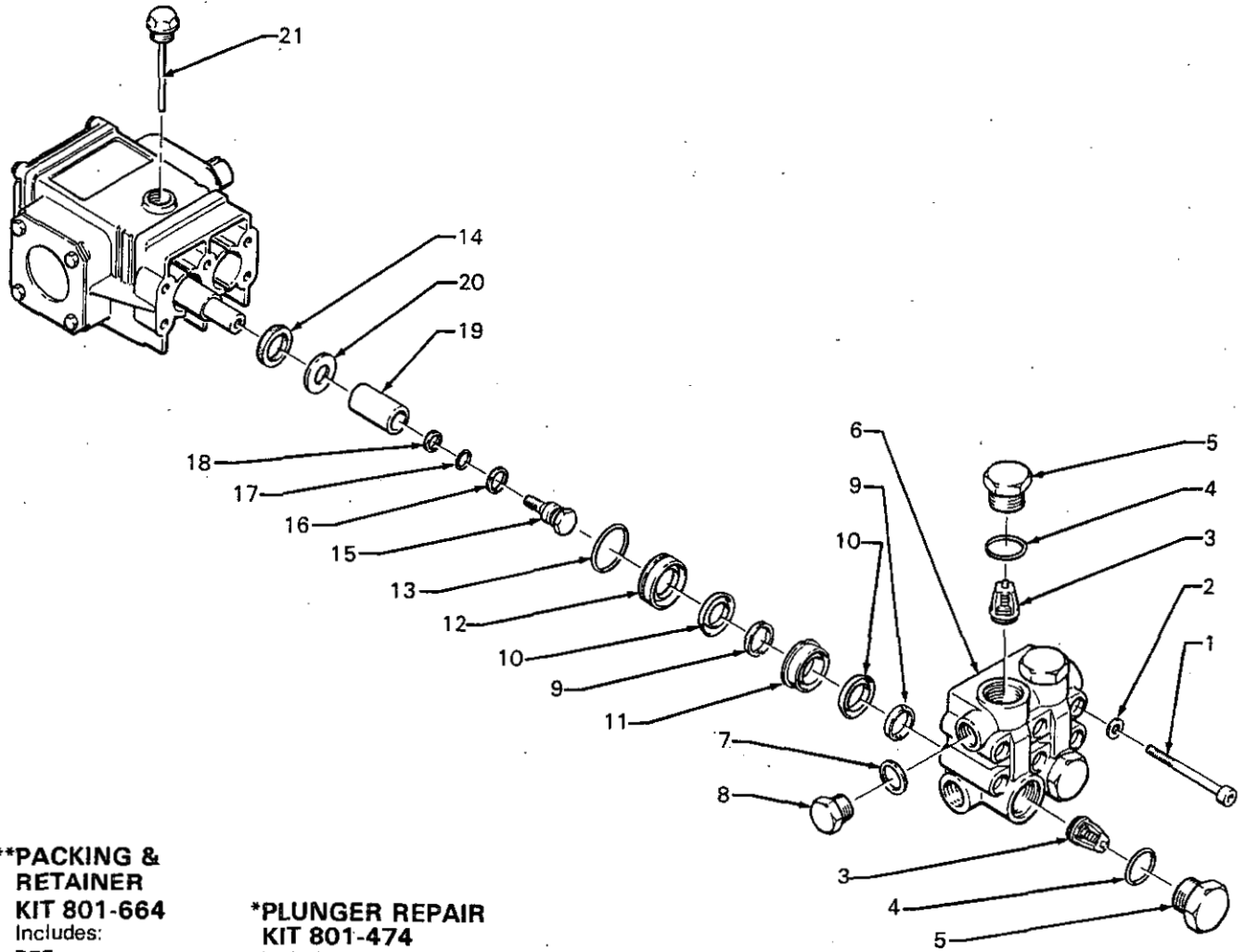

****PACKING & RETAINER KIT 801-664**
 Includes:

REF. NO.	QTY.
9	1
10	1
11	1
12	1
13	1

***PLUNGER REPAIR KIT 801-474**
 Includes:

REF. NO.	QTY.
15	3
16	3
17	3
18	3

***PACKING KIT 801-662**

Includes:

REF. NO.	QTY.
10	6

***OIL SEAL KIT 801-658**

Includes:

REF. NO.	QTY.
14	3

***VALVE UNIT KIT 801-472**

Includes:

REF. NO.	QTY.
3	6

* Pump repair kits indicated are standard kits for another model pump. Extra parts included in kits should be kept for future use.

** Two kits needed for entire pump.

PARTS LIST
Pump, 801-864

REF. NO.	PART NO.	DESCRIPTION	QTY	REF. NO.	PART NO.	DESCRIPTION	QTY
1	800-651	SCREW, M8 x 60 MM	6	12	801-656	PACKING RETAINER	2
2	801-652	WASHER, 8.4 x 13 x 0.8 MM	6	13	801-657	O-RING	2
3	801-472	VALVE UNIT	4	14	801-778	OIL SEAL	2
4	801-470	O-RING	4	15	801-493	PLUNGER RETAINING SCREW	2
5	801-471	HEX PLUG, M24 x 2 x 16 MM	4	16	801-492	WASHER	2
6	801-889	MANIFOLD	1	17	801-488	O-RING	2
7	801-485	WASHER	1	18	801-491	BACK-UP RING	2
8	801-484	CAP, 3/8 NPT	1	19	801-661	PLUNGER	2
9	801-655	HEAD RING	4	20	801-660	FLINGER	2
10	801-653	PACKING	4	21	801-659	OIL DIPSTICK	1
11	801-654	INTERMEDIATE RING	2				

Order parts by name and series letter of the assembly for which you are ordering.

SERVICE

Chemical Injector

The nozzle, check valve, valve seat, and needle valve may be cleaned by disassembling the chemical injector if clogging occurs within.

As with any injector, if the spray tip becomes clogged or if downstream restriction increases in any manner, the injector will stop drawing chemical. The restriction should be eliminated before continuing.

A retaining spring (17) has been installed at the factory to prevent the adjustment knob (15) from being unscrewed too far and the internal parts from falling out. This spring can be removed if the injector needs to be taken apart for cleaning. Be sure to leave spring in place whenever the pressure washer is being used. Removal of spring will not improve chemical flow but could cause chemical injector to quit working.

PARTS DRAWING

Chemical Injector

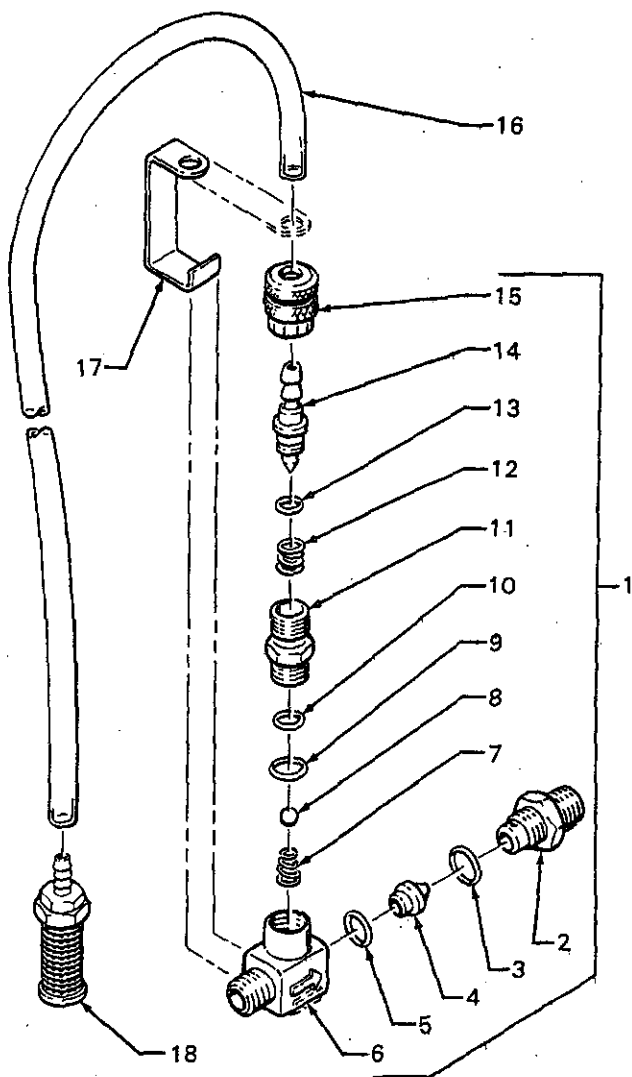

PARTS LIST

Chemical Injector

REF. PART NO. NO.	DESCRIPTION	QTY
1 800-138	CHEMJET NO. 2, includes items 2-15	1
2 801-684	NIPPLE, hex, brass, 3/8 NPT	1
3 801-685	O-RING	1
4 801-687	NOZZLE NO. 2, (16-21 l/min)	1
5 801-688	O-RING	1
6 801-689	CHEMJET BODY	1
7 801-690	SPRING, cone	1
8 *801-784	BALL	1
9 801-692	O-RING	1
10 801-693	O-RING	1
11 801-694	VALVE SEAT	1
12 801-695	SPRING	1
13 801-696	O-RING	1
14 801-697	NEEDLE/HOSE BARB	1
15 801-698	ADJUSTMENT KNOB	1
16 801-677	TUBING, 5/16 I.D.	1
17 801-682	SPRING, retaining	1
18 801-683	STRAINER	1

Order parts by name and series letter of the assembly for which you are ordering.

*Recommended "tool box" spare parts.

PARTS DRAWING
Gun Assembly, 800-157

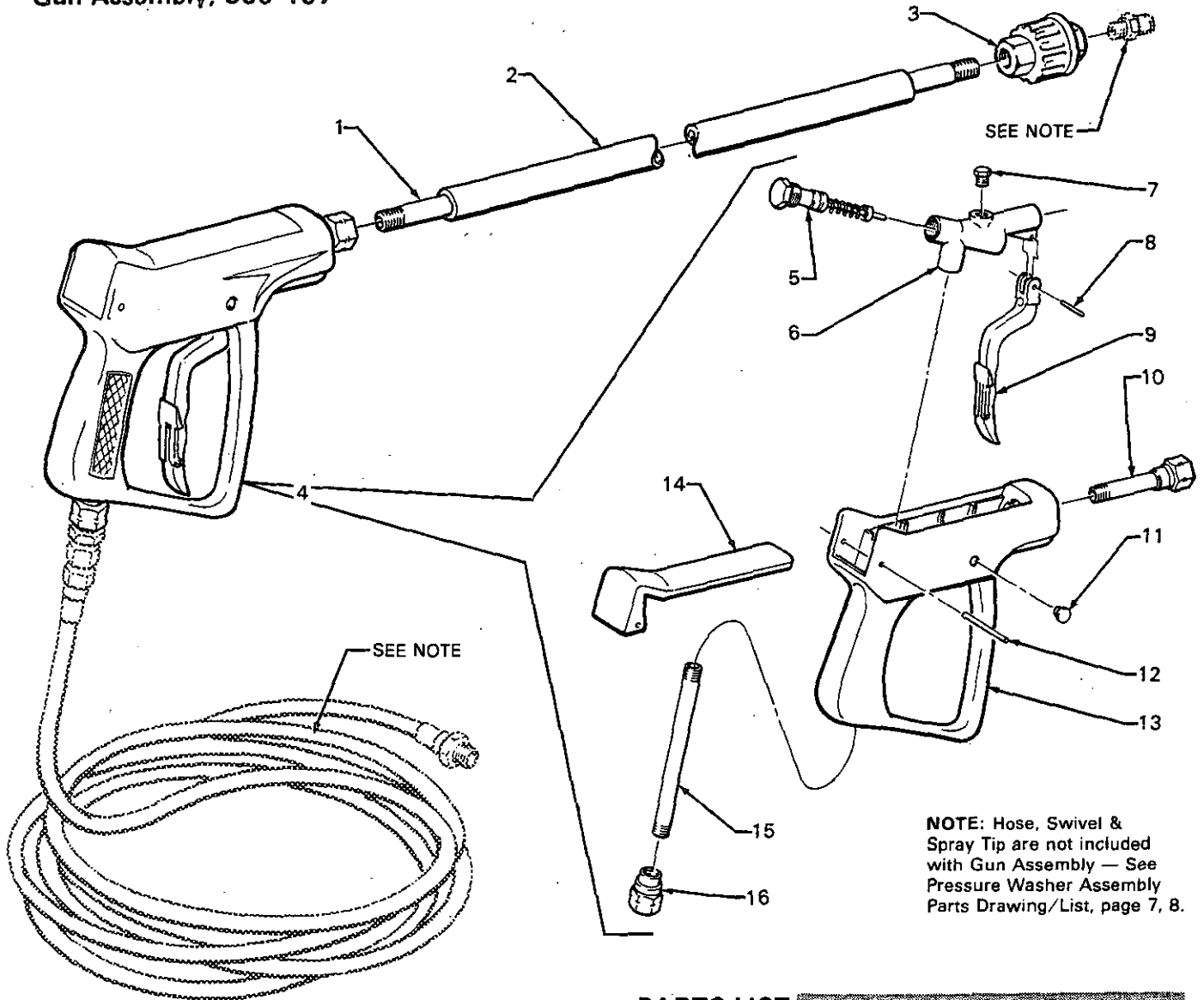

NOTE: Hose, Swivel & Spray Tip are not included with Gun Assembly — See Pressure Washer Assembly Parts Drawing/List, page 7, 8.

PARTS LIST
Gun Assembly, 800-157

REF. PART NO.	NO.	DESCRIPTION	QTY
1	801-935	WAND, 20"	1
2	801-957	GRIP	1
3	800-118	ADJUSTABLE NOZZLE	1
4	801-638	SPRAY GUN, (replaceable parts include items 5-16)	1
5	*801-639	CARTRIDGE	1
6	801-671	HOUSING	1
7	801-670	HEX PLUG	1
8	801-256	TRIGGER PIN	1
9	801-424	TRIGGER	1
10	801-672	OUTLET	1
11	801-673	PIN COVER	2
12	801-428	ACCESS PIN	1
13	801-419	HANDLE	1
14	801-427	ACCESS PLATE	1
15	801-420	TUBE	1
16	801-423	INLET FITTING	1

SERVICE
Gun, Cartridge Replacement

1. Press access pin (12) from gun handle and remove access plate (14) by sliding plate backwards. Remove cartridge (5) from housing (6) by using a 19 mm socket wrench.
2. Check inside housing to be sure all o-rings came out when cartridge was removed. If o-ring can be seen inside the housing, remove it, being careful not to damage internal threads in housing.
3. Throw away old cartridge and install new cartridge using a small amount of pipe sealant on threads. Be sure to tighten cartridge firmly against housing.
4. Slide access plate into place and install access pin.

Order parts by name and series letter of the assembly for which you are ordering.

* Recommended "tool box" spare parts.

ACCESSORIES (Must be purchased separately)

CHEMICAL CLEANING COMPOUNDS:

- General Purpose Cleaner 800-106
- Heavy Duty Degreaser 800-107
- Vehicle Wash 800-108
- Metal Pretreatment, Phosphatizer 800-109
- Paintable Rust Inhibitor 800-110

BACK FLOW PREVENTOR 801-133

Prevent back-up of contaminated water into fresh supply. Install upstream from pump.

TECHNICAL DATA

MOTOR: 1.5 hp, single phase
115 V, 60 Hz, 15 Amp

WATER PUMP: 800 psi (55 bar)
measured at pump
2.6 GPM (9.8 liter/min)

WETTED PARTS: Stainless Steel, Aluminum,
Phenolic Plastic, Ceramic
Liners, Nitrile Rubber

UNIT WEIGHT:	Cart Unit: 90 lb. (41 kg)	Handle Unit: 70 lb. (32 kg)
---------------------	-------------------------------------	---------------------------------------

OVERALL DIMENSION:

Length: 36 in. (914 mm)	Length: 22 in. (559 mm)
Width: 19 in. (483 mm)	Width: 10 in. (254 mm)
Height: 19.5 in. (495 mm)	Height: 14 in. (356 mm)

MAX. INLET WATER TEMPERATURE: 160°F (70° C)

INLET HOSE CONNECTION: 3/4" garden hose (f)

THE GRACO WARRANTY

Graco Inc. warrants all equipment manufactured by it and bearing its name to be free from defects in material and workmanship under normal use and service. This warranty extends to the original purchaser for a period of 12 months from the date of purchase and applies only when the equipment is installed and operated in accordance with written factory recommendations. This warranty does not cover damage or wear which, in the reasonable judgment of Graco, arises from misuse, abrasion, corrosion, negligence, accident, substitution of non-Graco parts, faulty installation or tampering.

This warranty is conditioned upon the prepaid return of the equipment claimed to be defective for examination by Graco to verify the claimed defect. If the claimed defect is verified, Graco will repair or replace free of charge, any defective parts. The equipment will be returned to the original purchaser transportation prepaid. If inspection of the equipment does not disclose any defect in workmanship or material, repairs will be made at a reasonable charge and return transportation will be charged.

THIS LIMITED WARRANTY IS EXCLUSIVE, AND IS IN LIEU OF ANY OTHER WARRANTIES (EXPRESS OR IMPLIED) INCLUDING WARRANTY OF MERCHANTABILITY OR WARRANTY OF FITNESS FOR A PARTICULAR PURPOSE AND OF ANY NON-CONTRACTUAL LIABILITIES INCLUDING PRODUCT LIABILITIES BASED ON NEGLIGENCE OR STRICT LIABILITY. EVERY FORM OF LIABILITY FOR DIRECT, SPECIAL OR CONSEQUENTIAL DAMAGES OR LOSS IS EXPRESSLY EXCLUDED AND DENIED.

EQUIPMENT NOT COVERED BY GRACO WARRANTY. Accessories or components of equipment sold by Graco that are not manufactured by Graco (such as electric motors, switches, hose, etc.) are subject to the warranty, if any, of their manufacturer. Graco will provide purchaser with reasonable assistance in making such claims.

Factory Branches: Atlanta, Dallas, Detroit, Los Angeles, West Caldwell (N.J.)
Subsidiary and Affiliate Companies: Canada; England; Switzerland; France; Germany; Hong Kong; Japan
GRACO INC. P.O. BOX 1441 MINNEAPOLIS, MN 55440-1444